

ST-8P Hinge

Position control · Constant torque

Features

- Designed for overmoulding
- Brings constant torque performance to a wide range of applications
- Space efficient design provides high torque in minimum space
- Never requires adjustment

Material

- Aluminum, plastic and hardened steel

Product Performance

- Cycle performance: 20,000 cycles within $\pm 20\%$ of static torque specification

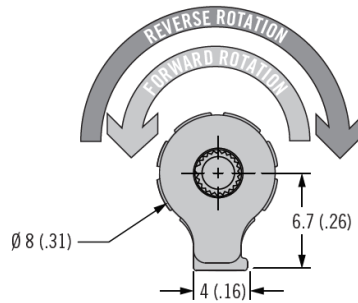
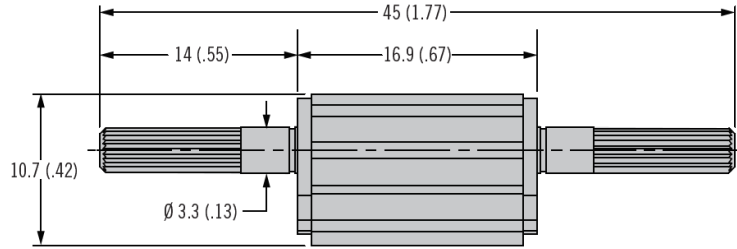

Symmetric Torque Versions	
Part Number	Static Torque (Forward and Reverse) N·m (in·lbf)
ST-8P-40SA-50	0.45 (4)
ST-8P-60SA-50	0.68 (6)
ST-8P-80SA-50	0.9 (8)

Asymmetric Torque Versions		
Part Number	Static Torque N·m (in·lbf)	
	Forward N·m (in·lbf)	Reverse N·m (in·lbf)
ST-8P-40FA-50	0.45 (4.0)	0.27 (2.4)
ST-8P-60FA-50	0.68 (6.0)	0.41 (3.6)
ST-8P-80FA-50	0.90 (8.0)	0.54 (4.8)
ST-8P-100FA-50	1.13 (10.0)	0.68 (6)
ST-8P-40RA-50	0.27 (2.4)	0.45 (4)
ST-8P-60RA-50	0.41 (3.6)	0.68 (6)
ST-8P-80RA-50	0.54 (4.8)	0.9 (8)
ST-8P-100RA-50	0.68 (6.0)	1.13 (10)